

REV	ECN #	DESCRIPTION	DRAWING	APPROVED	DATE
A		NEW RELEASE	DEYI		04/08/14

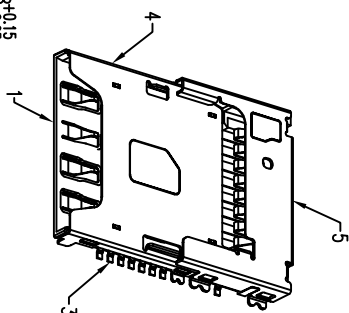
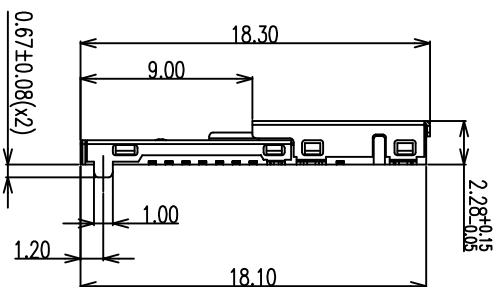
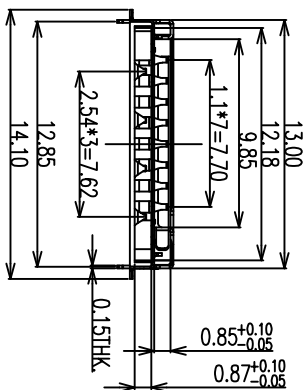
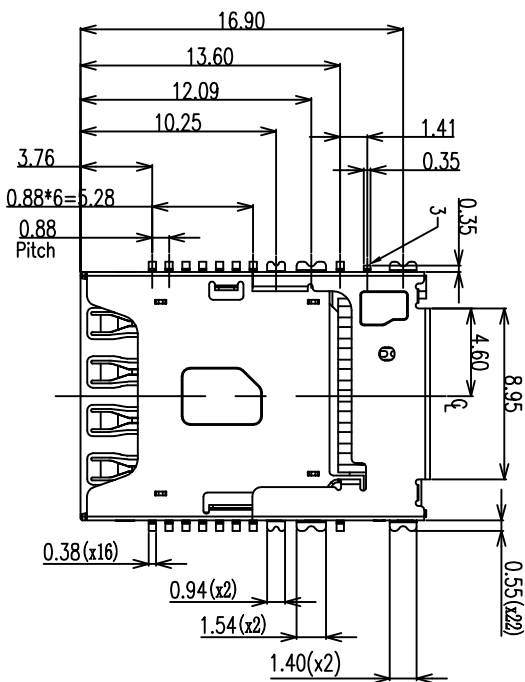
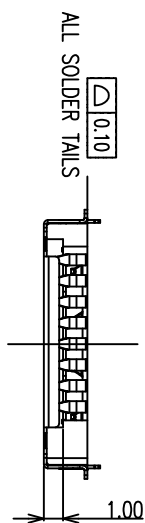

- NOTES:
- MATERIAL:
    - 1.1 HOUSING MATERIAL:THERMOPLASTIC U94V-0;COLOR:BLACK
    - 1.2 CONTACT MATERIAL:COPPER ALLOY.
    - 1.3. SHELL:STAINLESS STEEL
  - FINISH:
    - 2.1. CONTACT:AU PLAT CONTACT AREA;AU PLAT SOLDERING AREA;
    - 2.2. SHELL:AU PLAT SOLDERING AND SWITH AREA;

料号编码

SMA3-16 A B 05-00

① ② ③ ④ ⑤

① 产品系列: SMA3: MICRO SIM+MICRO SD

② 产品PIN数: 16: 16PIN

③ 塑胶材料: A: LCP

④ 塑胶颜色: B: 黑色

⑤ 产品流水号 00:

TABLE A:

ITEM	NAME	QTY	MATERIAL / FINISH
5	MICRO SD HELL	1	STAINLESS STEEL/SOLDER TAIL GOLD PLATED
4	MICRO SIM HELL	1	STAINLESS STEEL/SOLDER TAIL GOLD PLATED
3	DETECT CONTACT	1	COPPER ALLOY/CONTACT AREA GOLD PLATED
2	CONTACT	16	COPPER ALLOY/CONTACT AREA GOLD PLATED
1	HOUSING	1	HIGH TEMPERATURE UL 94-V0 BLACK

CUSTOMER DRAWING

YTCOON

Dongguan YTCOON Electronics Technology Co., Ltd

GENERAL TOLERANCE

X ±0.20

.XX ±0.15

.XXX ±0.10

ANGEL TOLERANCE

X ±3°

.XX ±2°

.XXX ±1°

DRAWING

DEYI

TITLE: 2.28H Micro SIM+MICRO SD二合一 带检测Pin双层卡座

APPROVED

P/N: SMA3-16AB05-00

DATE

2014.04.08

DRAWING NO. C-SMA3-00

UNIT

mm

SCALE

1:1

SIZE

A4

SHEET

10/2

REV

A

