

REV	ECN #	DESCRIPTION	DRAWING	APPROVED	DATE
A		NEW RELEASE	DEVI		12/11/12

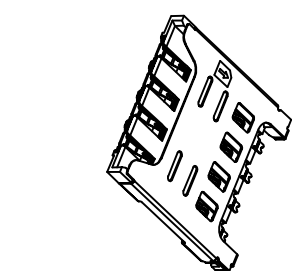
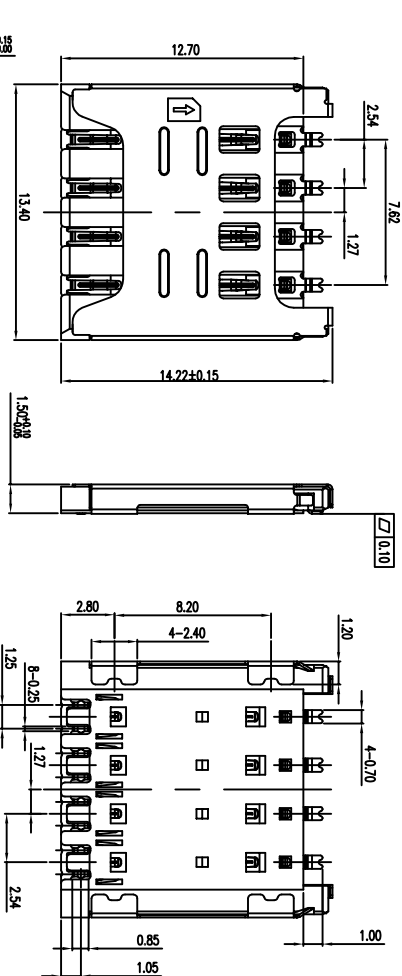

- NOTES:
1. MATERIAL:
 - 1.1 Housing: High Temperature Thermoplastic UL94V-0; Color: Black.
 - 1.2 Terminal: Copper Alloy.
 - 1.3 Shell: Stainless Steel
 2. FINISH:
 - 2.1 Terminal: Plated Gold on the Contact Area and Solder Tails, Underplated Nickel Over all.
 - 2.2 Shell: Plated Gold on the Solder Tails, Underplated Nickel Over all.
 3. SPECIALTY:
 - 3.1 Rated current: 0.5A
 - 3.2 Rated voltage: 30V
 - 3.3 Contact Resistance: 50mΩ MAX
 - 3.4 Insulation Resistance: 100MΩ MIN 100V DC
 - 3.5 Dielectric withstanding voltage: 100V AC.
 - 3.6 Solder ability: 235±5°C, 5±0.5s.
 - 3.7 Durability: 5000 Cycles Min.

料号编码

SM42-08 A B 05-00

① ② ③ ④ ⑤

- ① 产品系列: SM42: SIM CARD 简易式
- ② 产品PIN数: 08: 8PIN
- ③ 塑胶材料: A: LCP
- ④ 塑胶颜色: B: 黑色
- ⑤ 产品流水号: 00: 1.5H

PIN No	DESCRIPTION
C1	VCC : SUPPLY VOLTAGE
C2	RST : RESET SIGNAL
C3	CLK : CLOCK SIGNAL
C4	RESERVED
C5	GND
C6	VPP : VARIABLE SUPPLY VOLTAGE
C7	I/O : SERIAL DATA INPUT/OUTPUT
C8	RESERVED

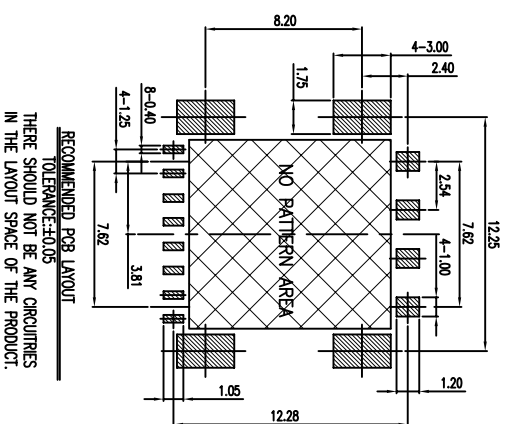
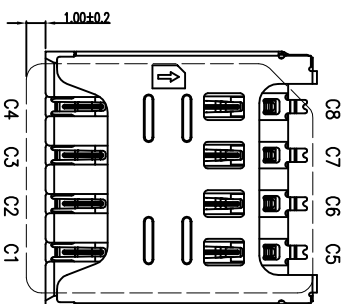

RECOMMENDED PCB LAYOUT
TOLERANCE: ±0.05
THERE SHOULD NOT BE ANY CIRCUITRIES
IN THE LAYOUT SPACE OF THE PRODUCT.

CUSTOMER DRAWING		YTCONN http://www.ytconn.com		Dongguan YTCNN <i>Electronics Technology Co., Ltd.</i>	
GENERAL TOLERANCE	DRAWING	DEVI	TITLE:	SIM 简易式卡座 (H=1.5mm)	
X: ±0.20	APPROVED		P/N:	SM42-08AB05-00	
.XX: ±0.15	DATE	2013.10.31	DRAWING NO.	C-SM42-00	
.XXX: ±0.10	UNIT	mm	SCALE	1:1	SIZE A4
ANGEL TOLERANCE			SHEET	1 of 1	REV
X: ±3°					A
.XX: ±2°					
.XXX: ±1°					